



SkyPro Outrigger, Angled; CW

Instruction Manual



Description

Designed to suspend the SkyPro Automatic Window Washer. A traction hoist is used to raise/lower the window washer (optional rear traction hoist mount with pulley assembly). The aluminum beam construction is light weight and corrosion resistant. Thanks to the telescoping design, the outrigger can adjust in height from 5 feet to 10 feet (based on a 4 foot scaffold frame being used). In addition, the 10ft backspan reduces the number of counterweights required.

Specifications

Part Number: 923021-22AC

Max. Load Capacity: 1,000 lb (450 kg)

Outreach: 38 to 54 in. (965 to 1372 mm)

Parapet Clearance: 5'-9" (1753mm) or
10'-9" (3277 mm)

Overall Dimensions LxWxH: 183x72x135 in.
(4648x1829x3429 mm)

Weight w/o winch or CW: 595 lb (270 kg)



Headquarters: 2145 Indian Road | West Palm Beach, Florida 33409 | Phone (888) or (561) 616-9003 | Fax (561) 616-9005

GENERAL WARNING - Read First

**Safety is a matter of life or death for riggers, operators and by-standers.
This warning is your share of duties for achieving safety.**

Your duty to understand and comply:

1. It is imperative for safety and efficiency of operations that this manual be read and fully understood by the rigger and the operator before rigging and using this equipment. All instructions contained herein must be carefully and strictly followed, including applicable Bee Access guidelines.
2. Should you hand over this equipment under any conditions, to any party operating out of your control, you must attach a clean copy of this manual and draw to other party's attention that strictly following all the instructions therein is a matter of life or death.
3. Before using this equipment, the rigger and the operator must become aware of all requirements of federal, state, provincial and local safety regulations, applicable to the entire suspended scaffold system and any component of it.
4. Never load this equipment above its rated load of **1000 lbs.**
5. Bee Access declines any responsibility for any special layouts, rigging or structural combinations beyond the descriptions of this manual.
6. Bee Access declines any responsibility for any other use of this equipment, than described in this manual.

Your duty to inspect and maintain:

7. Keep this manual available at all times for easy reference whenever required. Extra copies are available from Bee Access and/or your equipment supplier.
8. Carefully take notice of all labels affixed to the equipment. Never rig or operate this equipment if any label, normally fixed on it is obscured or missing. Replacement labels are available from Bee Access and/or your equipment supplier.
9. Every time the suspended scaffold is to be rigged or used, check that the Tieback Anchor, rigging, hoists, platform and other components are complete and in good working condition, prior to proceeding. All wire ropes and safety lines and their protective sleeves should be inspected at the beginning of every shift. Check for wear and abrasion due to contact with rigging equipment and/or the building structure.
10. **Inspection is to be carried out by personnel authorized by Bee Access once every twelve months.** Thoroughly check overall condition for bent, damaged or worn parts and broken welds. A signed and dated inspection record should be maintained for these purposes.
11. Make sure to comply with inspection and maintenance guidelines of all other components used in the suspended scaffold system.
12. Bee Access declines any responsibility for consequences of repairs or modifications brought out of its control to the product, specifically by replacement of original parts or repairs by another manufacturer.

Your duty to train and control people:

- Compliance with safety rules extends to rigging operations which must be carried out only after securing safe conditions of operation as per safety regulations and requirements.
13. An operator must not be assigned to rigging, de-rigging, moving or operating a suspended scaffold if that person is not:
 - a. Mentally and physically fit for the purpose, especially at heights
 - b. Competent for the job to be performed
 - c. Familiar with the scaffold equipment as rigged
 - d. Professionally trained for working under the above requirements
 14. Never let the equipment be moved or operated by unauthorized personnel. Keep the equipment, either rigged or unrigged, out of reach of unauthorized persons, while out of operation.
 15. Every suspended job must be placed under the control of a person having the required competence and authority for checking that all the instructions prescribed by this manual be regularly and efficiently carried out.

Your duty to safety of the entire scaffold system:

- A suspended scaffold system is made up of numerous pieces of equipment; all of these components can contribute to the required safety only if:
16. Other components meet the requirements of the applicable safety regulations and requirements, are of the proper quality, assembled to form a safe and efficient suspended system and compatibility is approved by Bee Access.
 17. The supporting structure and tie-backs can withstand every load to be applied, either static or dynamic, during rigging or operating of the suspended scaffold equipment.
 18. All the requirements in strength and resistance are obtained with the necessary safety coefficients (call your supplier for regulations and professional standards).
 19. All the calculations, design and subsequent work necessary to meet the above requirements have been made by a competent person on the basis of proper technical information regarding the site.

NOTE: This manual is neither a regulations compliance manual nor a general training guide on suspended scaffold operations. You must refer to proper instructions delivered by your supplier of the other pieces of equipment included in your suspended scaffold installation. Whenever calculations and specific rigging and handling are involved, the operator should be professionally trained to that end and secure relevant information prior to commencing such work.



Headquarters: 2145 Indian Road | West Palm Beach, Florida 33409 | Phone (888) or (561) 616-9003 | Fax (561) 616-9005

SkyPro Outrigger, Angled; CW

Parts List

Item	Qty.	Part No.	Description
1	1	821101	Shackle, 5/8"
2	1	822121	Data Tag, 2.5x4" SS
3	2	820124	Scaffold Frame, 5ft Wx4ft H
4	1	S1100-012	Front Wheel Assembly
5	1	S1100-013	Rear Wheel Assembly
6	2	820127	Diagonal Brace, 10ftx24
7	1	S1153-015	Outrigger Beam Assembly
8	2	S1101-031	Front Masthead Assembly
9	2	S1153-011	Beam Hinging Bracket Assembly
10	1	S1153-013	Brace & Telesoping Assembly
11	1	S1153-014	Telescoping Tube
12	1	N/A	10ft Aluma Plank 19in wide
13	1	920325	6in Pulley Bracket, 5x5 Front
14	1	920319	Hoist Mounting Bracket, 5x5
15	2	S1153-017	Beam Vertical Support Weldment
16	1	S1153-016	Eye Assembly

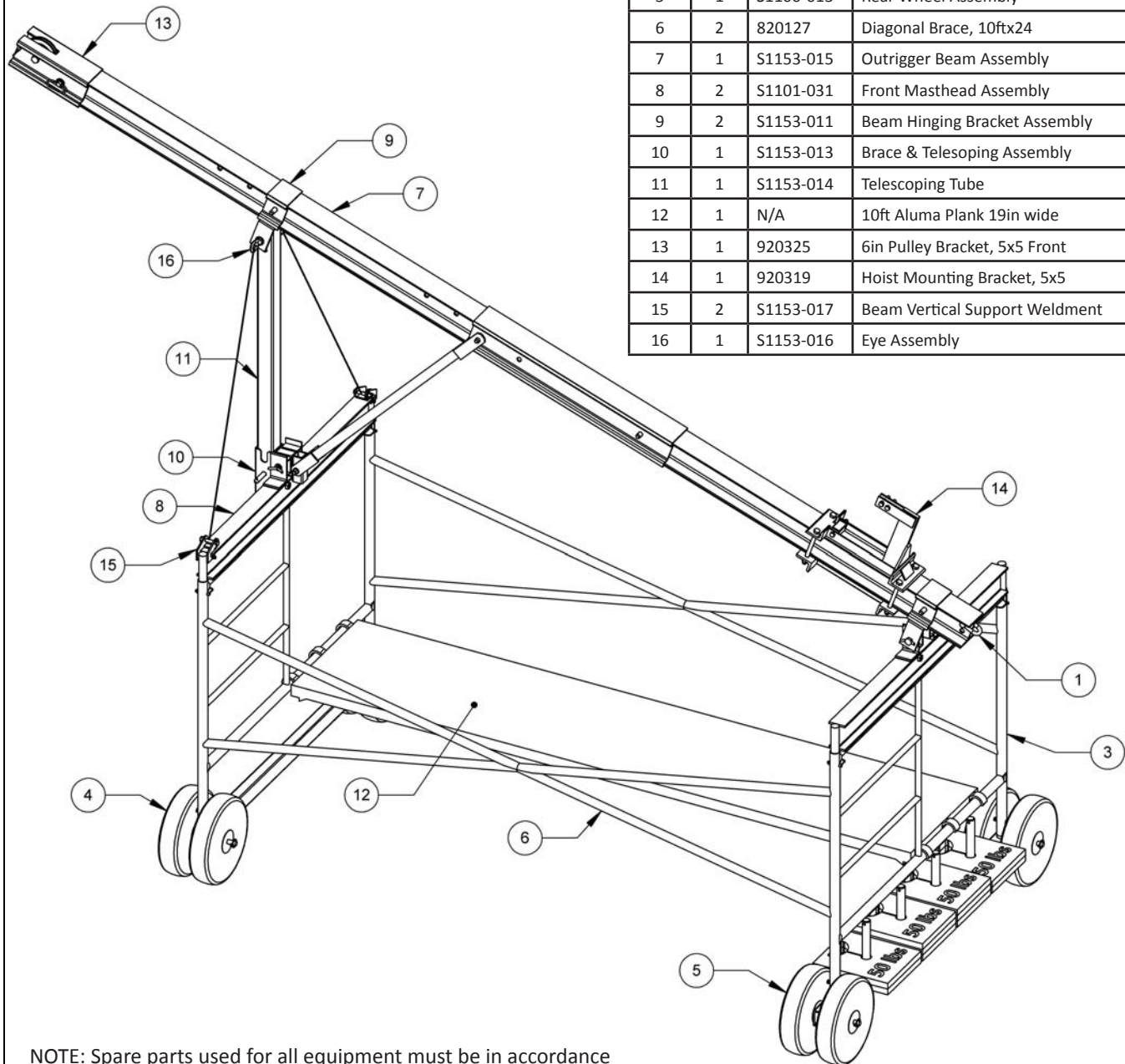

NOTE: Spare parts used for all equipment must be in accordance with the product, no substitutions are allowed.



SkyPro Outrigger, Angled; CW

Assembly Instructions

Tools Required

- (1) 3/4" Socket
- (1) 1-1/8" Socket
- (1) 3/4" Wrench
- (1) 1-1/8" Wrench

NOTE:

Assembly must be performed or supervised by a competent and trained person. Read and fully understand these instructions before proceeding with installation. Make sure warning/rating labels are in place, legible and have been read.

Assembly Instructions:

1. Slide Splice Tube onto Rear Beam and pin into location with 3/4" Quickpin (Note the location of the holes in the Splice Tube and Rear Beam in the picture below).
2. Slide Front Beam into Splice Tube and pin into location with 3/4" Quickpin (Note the location of holes in the Splice Tube and Front Beam in the picture below).
3. Slide Beam Hinging Bracket Assembly onto Rear Beam and pin into position with 3/4" Quickpin.
4. Slide Beam Hinging Bracket Assembly onto Front Beam and pin into position with 3/4" Quickpin.
5. Slide 6" Pulley Bracket, 5x5 Front Assembly onto Front Beam and pin into position with 3/4" Quickpin.

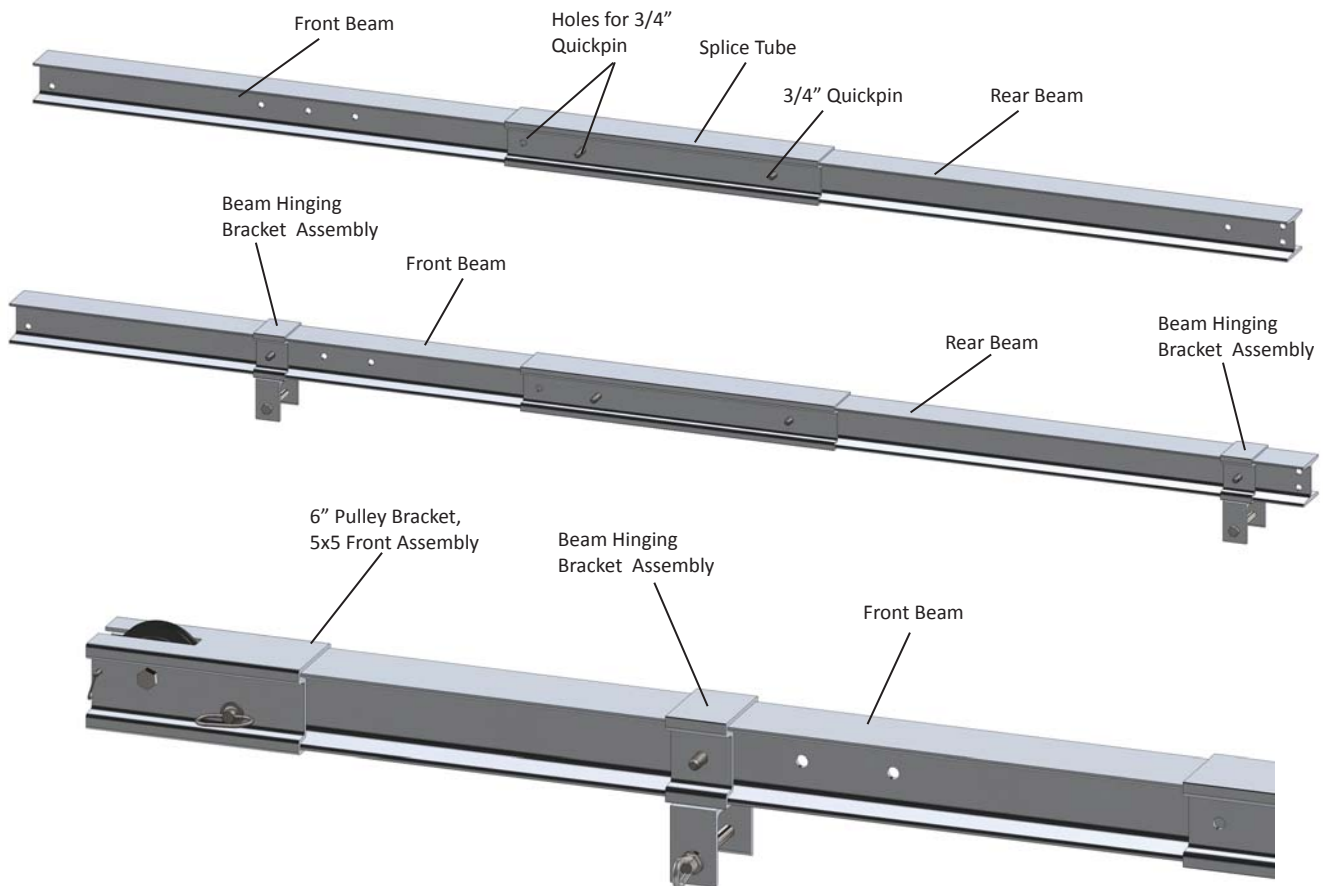

! WARNING:

- Never use equipment for purposes or in ways for which it was not intended.
- All bolts must be secured to their proper torque rating (3/8" = 20 ft/lbs) (1/2" = 35 ft/lbs) (3/4" = 50 ft/lbs).
- Any installation of this equipment other than in strict accordance with these instructions shall be at the Operator's risk and may result in death or serious injury.
- It is the users responsibility to ensure that the structure on which the outrigger is placed will support 3,625 lb (1644 kg) Ultimate Load (906 lb (411 kg) per wheel).



SkyPro Outrigger, Angled; CW

Assembly Instructions

Assembly Instructions (continued):

6. Insert Scaffold Frame, 5ft Wx4ft H (#3) onto Front Wheel Assembly (#4) using the provided 3/8" x 3.0" bolts washers and lock nuts. NOTE: The wheel needs to be removed to perform this task.

7. Insert Scaffold Frame, 5ft Wx4ft H (#3) onto Rear Wheel Assembly (#5) using the provided 3/8" x 3.0" bolts washers and lock nuts. NOTE: The wheel needs to be removed to perform this task.

8. Attach Diagonal Brace (#6) to the Scaffold Frame (#3).

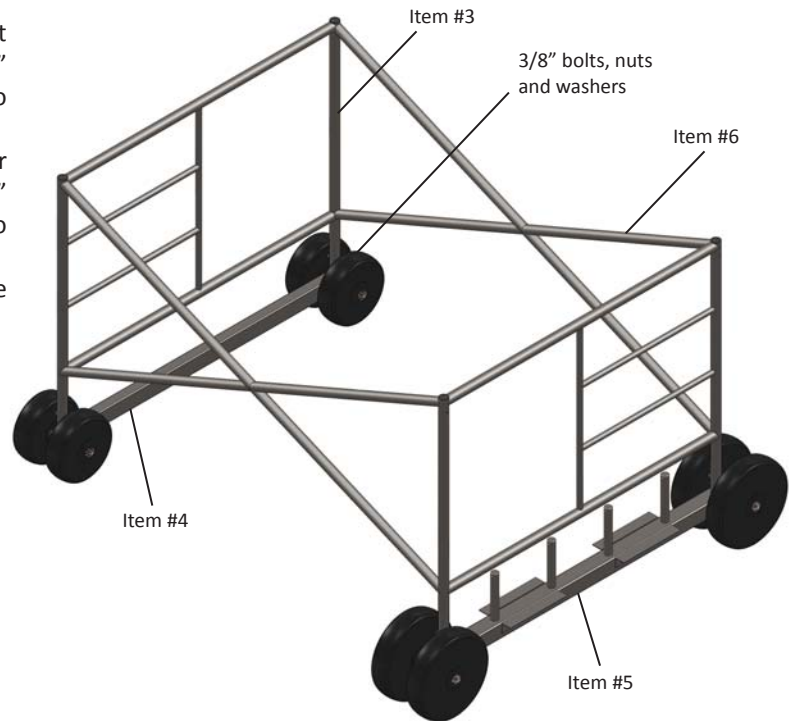

9. Attach Masthead Assembly (#8) to BOTH Scaffold Frames (#3) using the provided Hitch Pin.

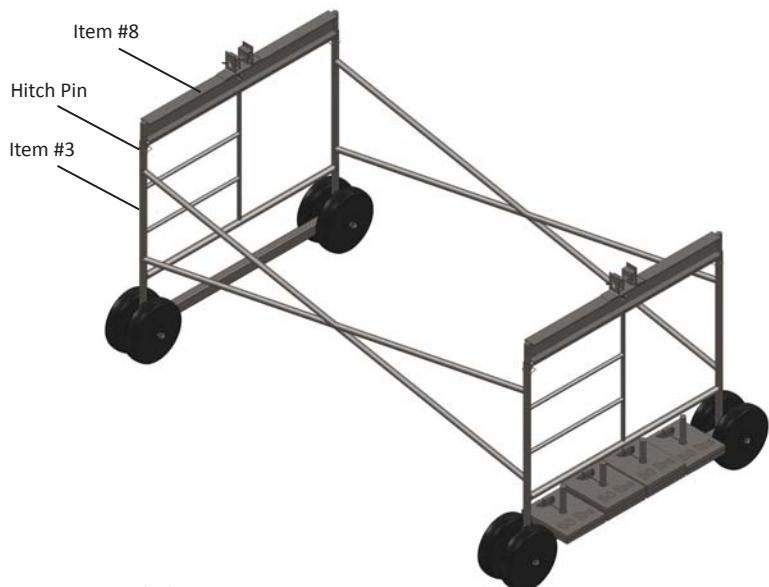

WARNING

- Never use equipment for purposes or in ways for which it was not intended.
- All bolts must be secured to their proper torque rating (3/8" = 20 ft/lbs) (1/2" = 35 ft/lbs) (3/4" = 50 ft/lbs).
- Any installation of this equipment other than in strict accordance with these instructions shall be at the Operator's risk and may result in death or serious injury.
- It is the users responsibility to ensure that the structure on which the outrigger is placed will support 3,625 lb (1644 kg) Ultimate Load (906 lb (411 kg) per wheel).



SkyPro Outrigger, Angled; CW

Assembly Instructions

Assembly Instructions (continued):

10. Install the Brace & Telescoping Assembly (#10) to the Masthead (#8) with the provided 3/4" Quickpins and washers. (Note that the vertical square tube is on the outside of the scaffolding frame assembly).

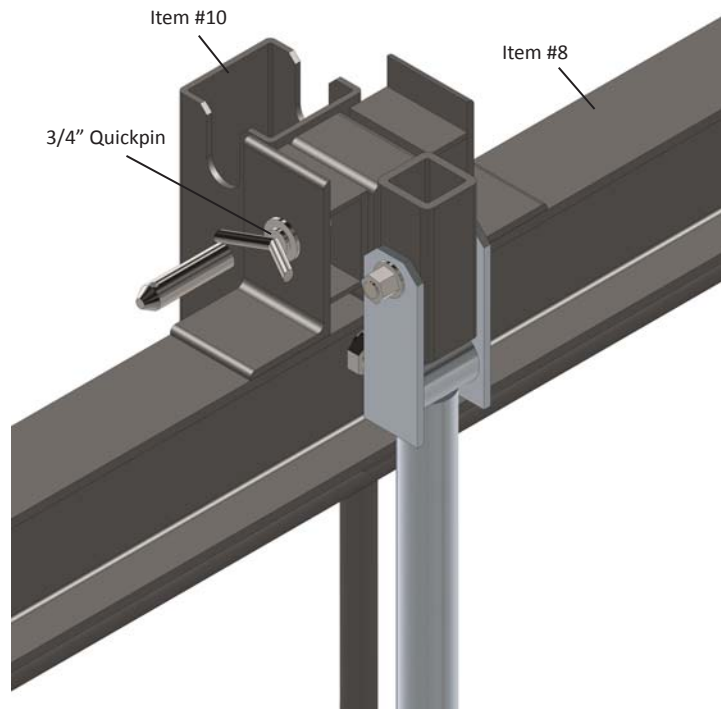

11. Slide the Telescoping Tube (#11) into the Brace & Telescoping Assembly (#10) and pin into position with the provided 3/4" Quickpin.

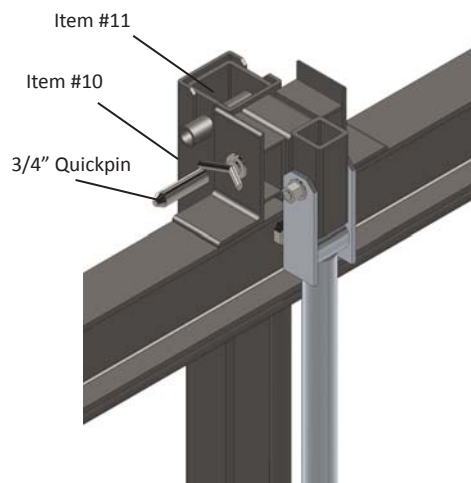

WARNING

- Never use equipment for purposes or in ways for which it was not intended.
- All bolts must be secured to their proper torque rating (3/8" = 20 ft/lbs) (1/2" = 35 ft/lbs) (3/4" = 50 ft/lbs).
- Any installation of this equipment other than in strict accordance with these instructions shall be at the Operator's risk and may result in death or serious injury.
- It is the users responsibility to ensure that the structure on which the outrigger is placed will support 3,625 lb (1644 kg) Ultimate Load (906 lb (411 kg) per wheel).



SkyPro Outrigger, Angled; CW

Assembly Instructions

Assembly Instructions (continued):

- Place Outrigger Beam Assembly (#7) onto Masthead Assemblies (Item #8).
- Pin the Beam Hinging Bracket Assembly (#9) to the Rear Masthead (#8).
- Attach the Beam Hinging Bracket Assembly (#9) to the Telescoping Tube (#11) with the Eye Assembly (#16).
- Slide EACH Beam Vertical Support Weldment (#15) onto the end of the Masthead (#8) and secure the the Eye Assemblies wire rope.

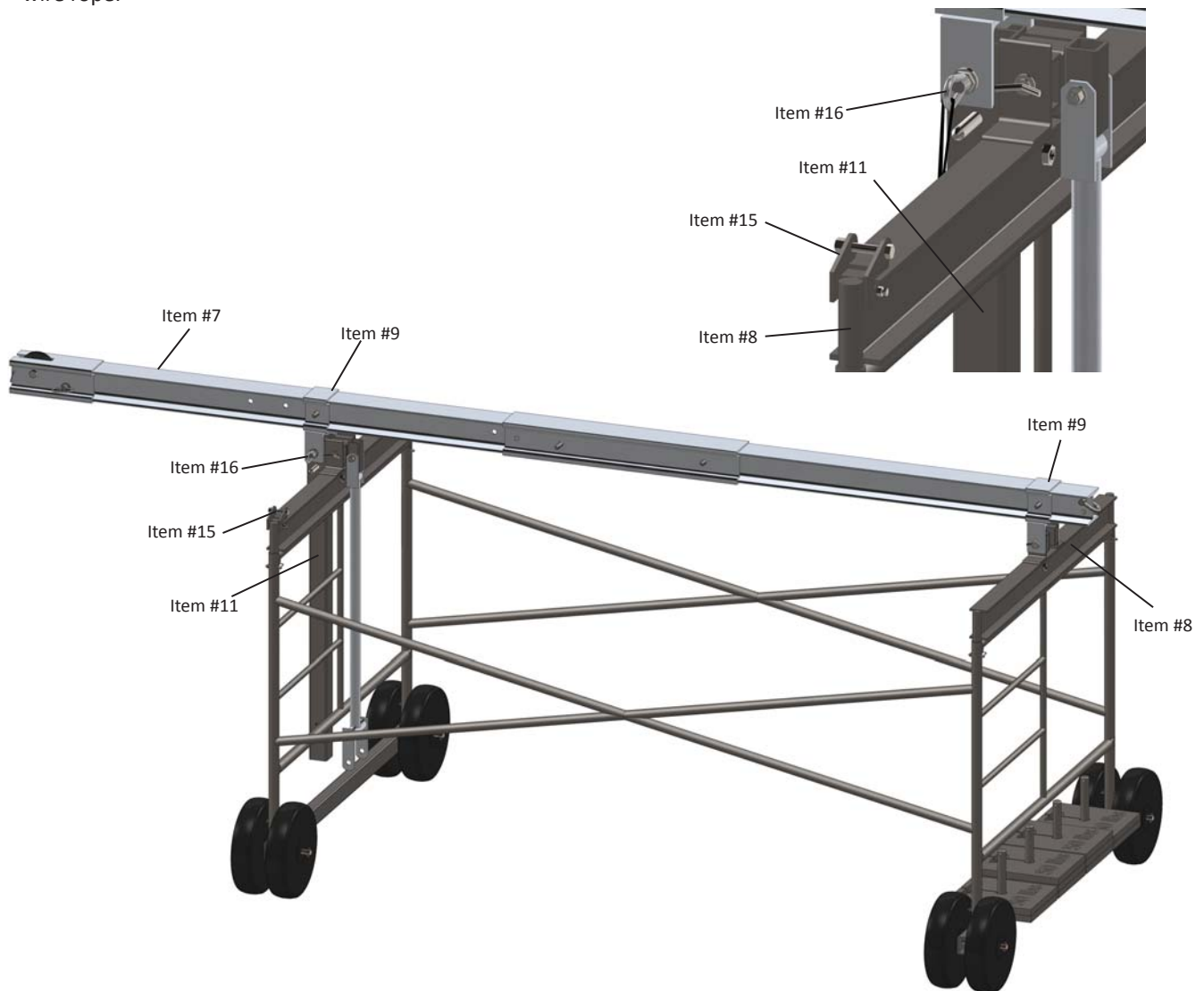

WARNING

- Never use equipment for purposes or in ways for which it was not intended.
- All bolts must be secured to their proper torque rating (3/8" = 20 ft/lbs) (1/2" = 35 ft/lbs) (3/4" = 50 ft/lbs).
- Any installation of this equipment other than in strict accordance with these instructions shall be at the Operator's risk and may result in death or serious injury.
- It is the users responsibility to ensure that the structure on which the outrigger is placed will support 3,625 lb (1644 kg) Ultimate Load (906 lb (411 kg) per wheel).



SkyPro Outrigger, Angled; CW

Assembly Instructions

Assembly Instructions (continued):

- Secure 10ft Aluma Plank (#12) to the Scaffolding Frame (#3).
- Attach the Hoist Mounting Bracket, 5x5 (#14) to the Outrigger Beam Assembly (#7) using the provided 1/2" bolts, washers and lock nuts.

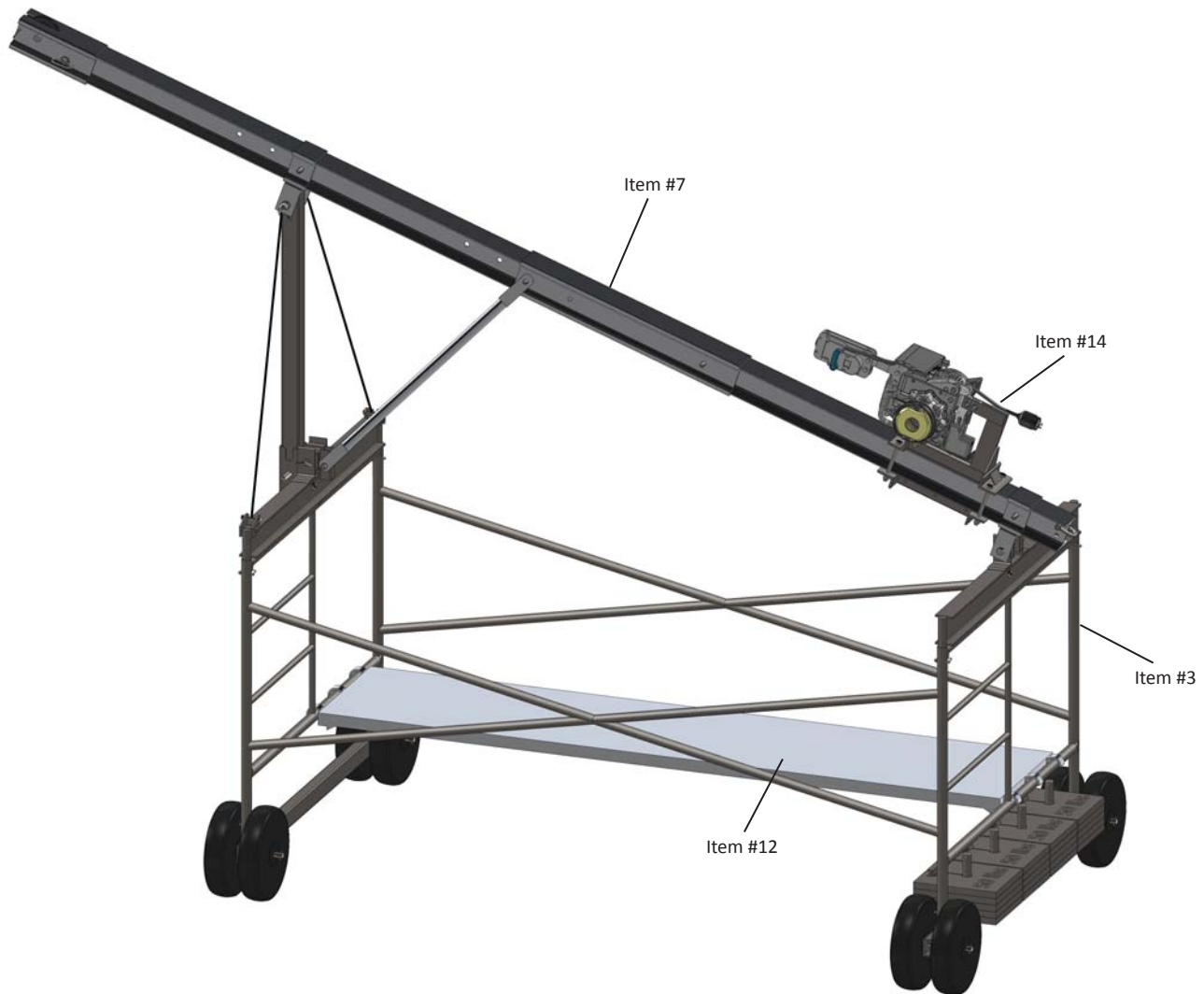

WARNING

- Never use equipment for purposes or in ways for which it was not intended.
- All bolts must be secured to their proper torque rating (3/8" = 20 ft/lbs) (1/2" = 35 ft/lbs) (3/4" = 50 ft/lbs).
- Any installation of this equipment other than in strict accordance with these instructions shall be at the Operator's risk and may result in death or serious injury.
- It is the users responsibility to ensure that the structure on which the outrigger is placed will support 3,625 lb (1644 kg) Ultimate Load (906 lb (411 kg) per wheel).



SkyPro Outrigger, Angled; CW

Beam Hole Locations

Raised "UP" Position

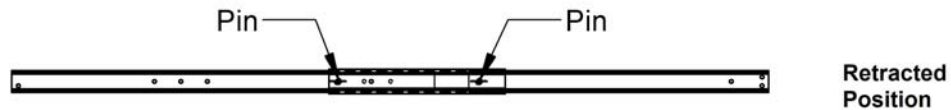
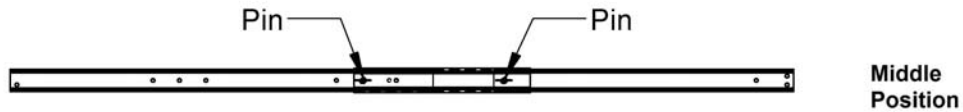

Lowered "DOWN" Position



WARNING:

Calculations are prepared and tests have been done with a 2.5 to 1 safety factor on the suspension wire rope. Do NOT exceed the limits of this system as outlined in this manual. Doing so may result in death or serious injury.

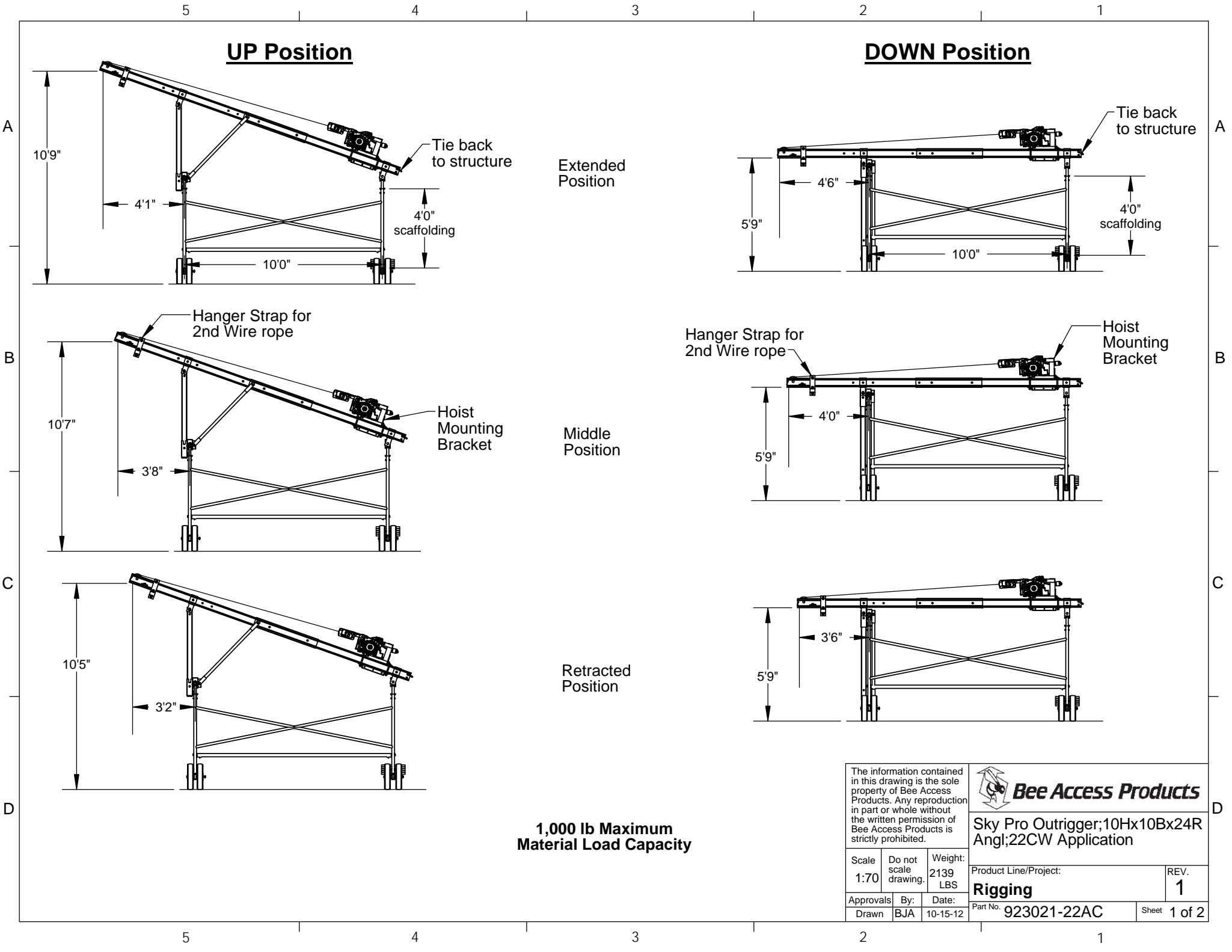

UP Position

DOWN Position

Extended Position

Middle Position

Retracted Position

**1,000 lb Maximum
Material Load Capacity**

The information contained in this drawing is the sole property of Bee Access Products. Any reproduction in part or whole without the written permission of Bee Access Products is strictly prohibited.



Bee Access Products

Sky Pro Outrigger; 10Hx10Bx24R Angl; 22CW Application

Scale: 1:70
Do not scale drawing.

Weight: 2139 LBS

Product Line/Project:

REV. 1

Approvals Drawn By: BJA Date: 10-15-12

Rigging
Part No. 923021-22AC Sheet 1 of 2

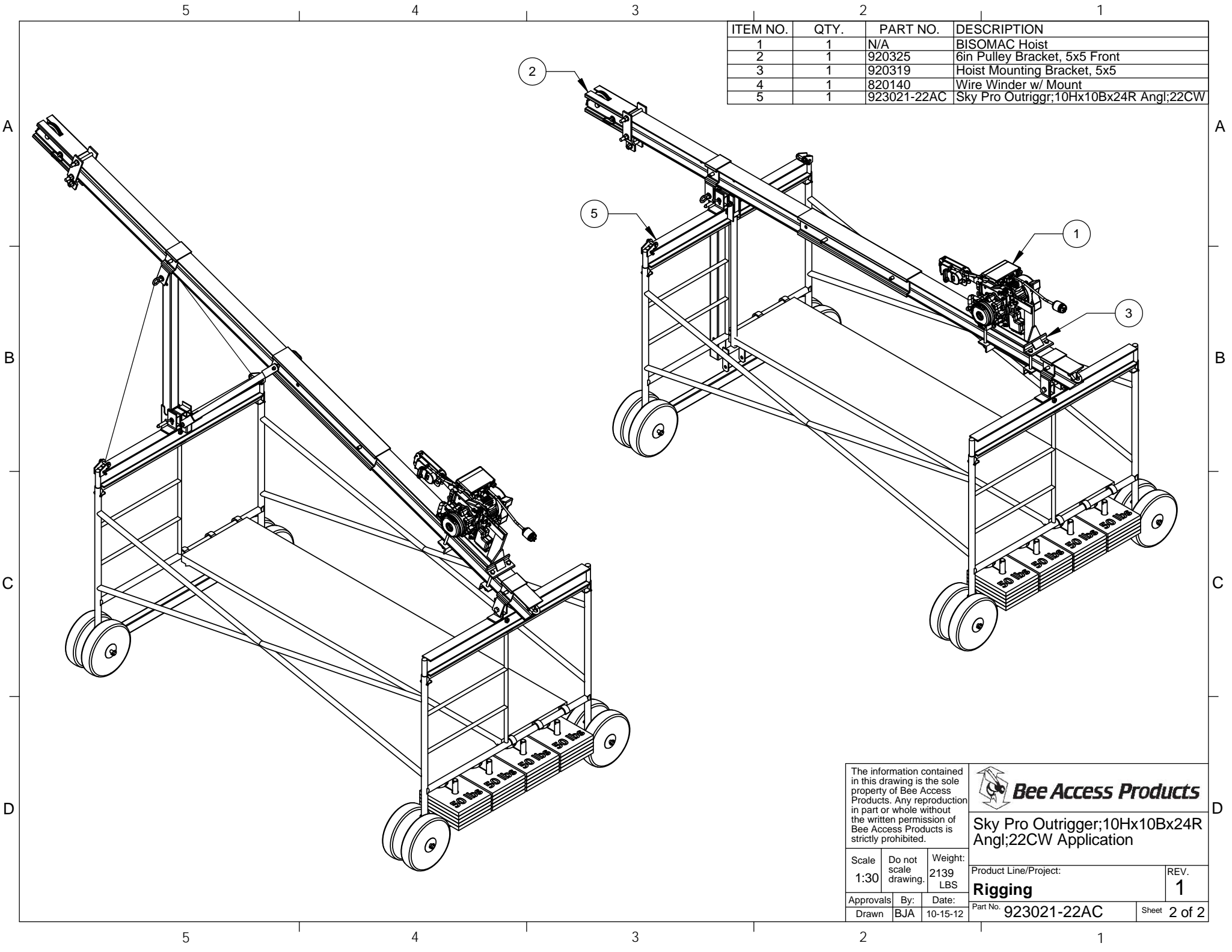

ITEM NO.	QTY.	PART NO.	DESCRIPTION
1	1	N/A	BISOMAC Hoist
2	1	920325	6in Pulley Bracket, 5x5 Front
3	1	920319	Hoist Mounting Bracket, 5x5
4	1	820140	Wire Winder w/ Mount
5	1	923021-22AC	Sky Pro Outrigger; 10Hx10Bx24R Angl; 22CW

The information contained in this drawing is the sole property of Bee Access Products. Any reproduction in part or whole without the written permission of Bee Access Products is strictly prohibited.



Sky Pro Outrigger; 10Hx10Bx24R Angl; 22CW Application

Scale: 1:30
Do not scale drawing.
Weight: 2139 LBS

Product Line/Project: **Rigging** REV. **1**

Approvals Drawn: BJA Date: 10-15-12

Part No. **923021-22AC** Sheet 2 of 2